



JET PACK BALLOON RACES

Do you have what it takes to beat your opponent?

WHAT YOU NEED

- 2 Chairs
- 2 Balloons
- 2 Pieces of String (10-15 feet long)
- Double-Sided Tape
- 2 Drinking Straws
- 1 Pair of Scissors

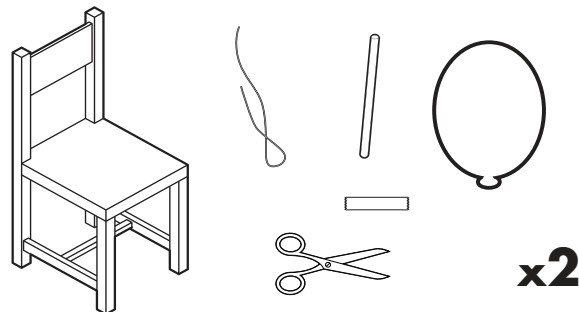

INSTRUCTIONS

- 1 Create your race course by placing two chairs approximately 10 - 15 feet apart. If two chairs are not available use a table and a chair, or any stable elevated objects that are a few feet from the ground.
- 2 Tie or tape 2 strings about a foot apart between chairs and make sure the string is pulled taut. Your race course is ready!
- 3 Cut straws completely down the lengthwise side of straw (do not cut the straw in half). Then wrap the cut straws around the strings.
- 4 Blow up balloons (but do not tie off).
- 5 Using the double-sided tape, tape the balloons to the straws. Nowm you're ready to race!!!
- 6 On your mark, get set, LET'S GOOOO!!! The first racer to get to the other end of the course is the Jetpack race winner!

